



**HIGH POWER STEREO SPEAKER SELECTOR  
MODEL:PSPVC4/PSPVC6**



Thank you for purchasing PYLE PRO Multi-Speaker Selectors. It lets you connect up to four (PSPVC4) or six (PSPVC6) separate pairs of speakers to your stereo receiver/amplifier. The control center is especially convenient if you have speaker sets in different rooms and want to turn them on and off independently. You can enjoy the convenience and flexibility of listening to multiple speaker pairs simultaneously.

The control center lets you use one to four (PSPVC4) or six (PSPVC6) sets of speakers at a time, and is designed to operate with a stereo receiver/amplifier that has a maximum of 100 watts per channel, and with speaker systems that have a minimum impedance of 8 ohms (see "Impedance Chart" on page 6)

## **PREPARATIONS**

- Use the PYLE PRO Speaker Selectors only with amplifiers rated at 100 watts per channel or less.
- Your PYLE PRO Speaker Selector is designed to accept any size cable up to 14 gauge non-terminated speaker wire. If you're using non-terminated speaker wire, do not use any speaker wire that is larger than 14 gauge. The lower the gauge number, the larger the cable (e.g., 12 gauge is larger in actual physical size than 14 gauge).
- Do not hook the outputs of one selector into the inputs of another speaker selector together.
- Before you connect the AC power source, make sure you set ALL speakers ON/OFF to OFF
- Left and right "commons" are isolated to work with all types of amplifiers
- Auto transformer impedance protection.

PSPVC4

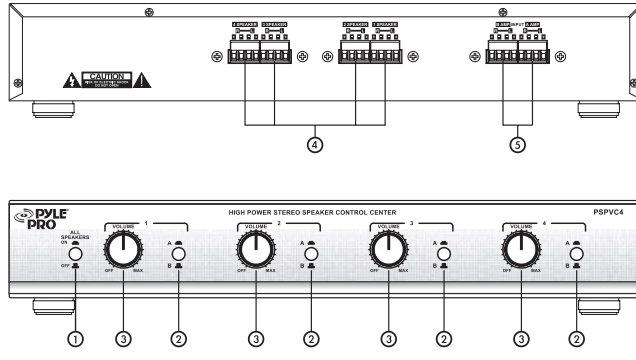

PSPVC6

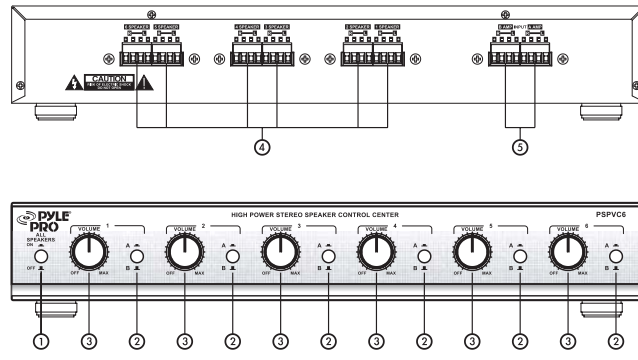

## **OPERATION**

### **1. Speakers on/off Button**

Press button in to turn on all speaker pairs.

Press again button out to turn off.

### **2. Amplifier A/B Selector Button**

Press button to select amplifier A and B.

### **3. Volume Controls**

Turn the control knob clockwise to increase the volume and counter-clockwise to decrease or off.

### **4. Speaker Connections**

The control center divides the power from your receiver/amplifier differently to its speaker terminals. (This is especially noticeable when you connect only one pair of speakers. If you connect more than one pair of speakers, see "Impedance Chart" on page 4 to selector the best terminals to connect.) For the best performance, make the connections based on how frequently you use each set of speakers.

Cautions :To avoid damaging your speakers or receiver/amplifier:

- Be sure your receiver/amplifier's power is turned off before you make the connections.
- Never let the speaker wire's bare ends touch each other or the adjacent terminals on the control center.
- Do not connect more than one pair of speakers to each set of terminals.

## 5. Amplifier Connections

Connect the speaker output of your receiver or amplifier (100watts max.). If you are using a second amplifier, connect it to the B amp terminal.

Maximum Amplifier input

100W RMS

150W AVG

Maximum Output per Speaker

18W RMS

50W AVG

100W PEAK

4 or 16 OHMS LOAD.

Insert the speakers' positive (+) wires in the positive terminals, and negative (-) wires into the negative terminals, according to the respective L (left) and R (right) terminals.

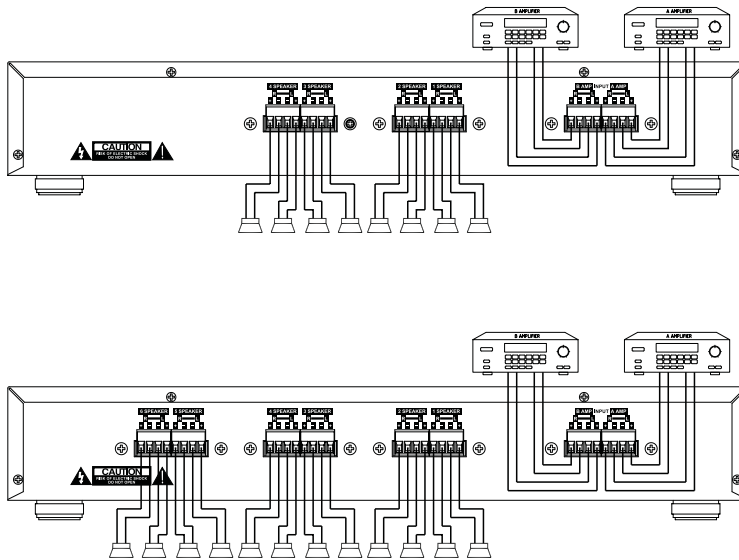

Insert your receiver/amplifier's positive (+) wires into the positive terminals, and negative (-) wires in the negative terminals.

Notes :

- If your receiver/amplifier has more than one set of speaker terminal (A and B), connect only one or the other to the control center.
- For the best results, we recommend 14-gauge, two conductor speaker wire (not supplied) for most connections. If you plan to locate the speakers further than 80 feet from the control center, use a heavier gauge of wire.

## IMPEDANCE CHART

Impedance is a measurement of the load placed on your receiver/amplifier by the speakers. The load placed on your receiver/amplifier from the control center will vary depending on how many pairs of speakers you turn on at one time, and on which speakers you turn on. The chart below shows the impedance for all possible combinations of 8-ohm speakers.

PSPVC4

Speaker Sets On	Impedance ( $\Omega$ )
A, B, C or D	8
A+B, A+C, A+D B+C, B+D, C+D	4
A+B+C, A+B+D, A+C+D, B+C+D	3.1
A+B+C+D	2.4

PSPVC6

Speaker Sets On	Impedance ( $\Omega$ )
A, B, C, D, E or F	8
A+B, A+C, A+D, A+E, A+F, B+C, B+D, B+E, B+F, C+D, C+E, C+F, E+F	4
A+B+C, A+B+D, A+B+E A+B+F, A+C+D, A+C+E A+C+F, A+D+E, A+D+F A+E+F, B+C+D, B+C+E B+C+F, B+D+E, B+D+F C+D+E, C+D+F, D+E+F	3.1
A+B+C+D, A+B+C+E A+B+C+F, A+C+D+E A+C+D+F, A+D+E+F B+C+D+E, B+C+D+F C+D+E+F	2.4
A+B+C+D+E+F	1.7

## SPECIFICATIONS

Audio Power Handling	50W (R.M.S.)/CH, 100W (Max)/CH
Frequency Response	20 Hz to 20KHz
Channel Separation	80 dB
Crosstalk between channels	50 dB
Speaker terminal wire size requirements	14-22 gauge
Dimensions (WxHxD)	430x77x160 mm (PSPVC4/PSPVC6)
Weight	4.0kgs (8.82lbs) (PSPVC4) 5.0kgs (11.02lbs) (PSPVC6)